

WK-CNT Weatherproofing Kit for Connectors and Antennas

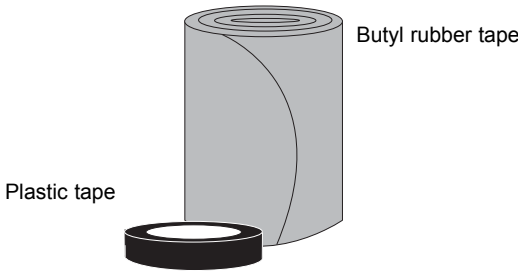

Due to the variability in design of connector interfaces, special attention must be given to the application of weatherproofing materials. The following illustrations demonstrate the recommendations of Andrew Corporation in cases where there is ample access to the connection.

Jumper Cable to Device Connection

1 Tighten the connection with a torque wrench to the proper torque value to ensure that correct internal seals and surface contacts are made.

Torque wrench	Connector type	Torque
Andrew 244377	7-16 DIN	18 - 22 lb-ft
Andrew 244379	N	15 - 25 lb-in

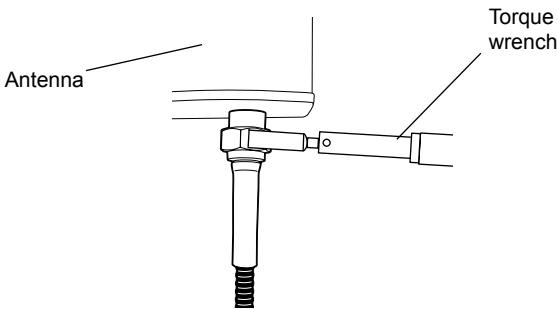

Tighten connection

2 Wrap the connection with a layer of 3/4" (19 mm) plastic tape, starting at 1" (25 mm) from the connector. Overlap the tape to half-width and extend the wrapping to the flange of the device connector. Avoid making creases or wrinkles. Smooth the tape edges.

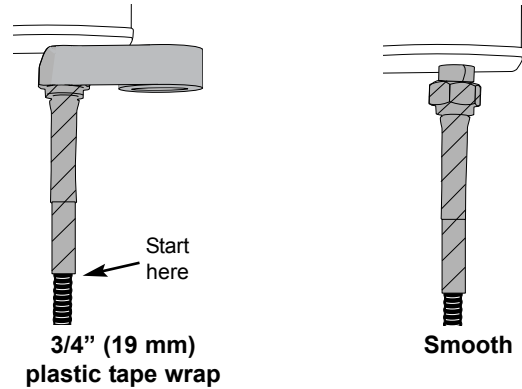
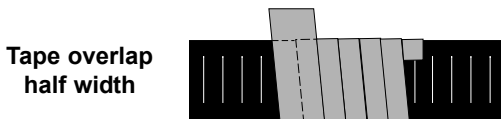

3/4" (19 mm) plastic tape wrap

Smooth

3 Cut an 5" (125 mm) length of rubber tape. Expand the width of the tape by stretching it so that it will wrap completely around the connector and cable. Do not tear tape. Wrap the tape around the cable connector and the cable. Press the tape edges together so that there are no gaps. Press the tape against the connection and cable. The tape should extend 1" (25 mm) beyond the plastic tape on the jumper.

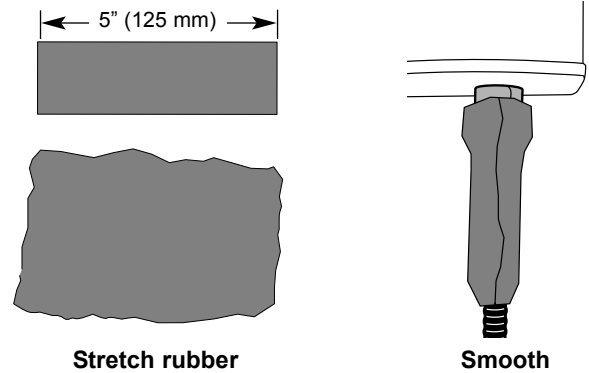

Stretch rubber

Smooth

4 Start wrapping a layer of 3/4" (19 mm) plastic tape 1" (25 mm) below the rubber tape, overlapping at half width. Finish the wrap at the flange of the device connector and cut the tape. Repeat this process for a second and third layer. Smooth the tape edges.

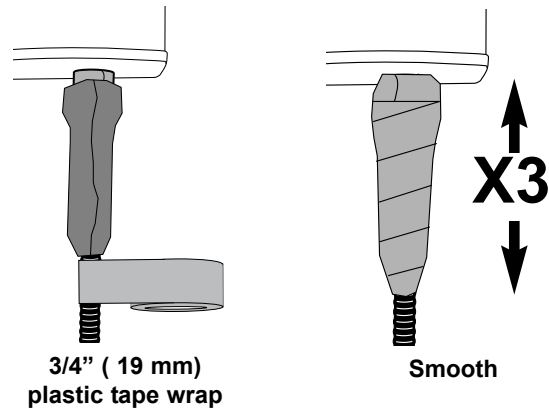

3/4" (19 mm) plastic tape wrap

Smooth

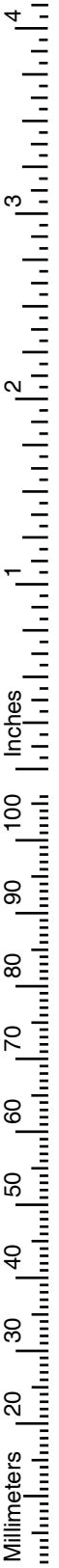

Feeder Cable to Jumper Cable Connection

1 Tighten the connection with a torque wrench to the proper torque value to ensure that correct internal seals and surface contacts are made.

Torque wrench	Connector type	Torque
Andrew 244377	7-16 DIN	18 - 22 lb-ft
Andrew 244379	N	15 - 25 lb-in

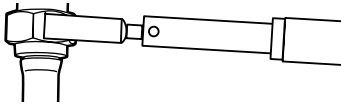

2 Prepare the cable by removing any cable markers and drying the cable and connectors. Starting at 2" (51 mm) from the feeder connector, wrap the connection with a layer of 3/4" (19 mm) plastic tape. Overlap the tape to half-width and extend the wrapping 2" (51 mm) beyond the jumper connector.

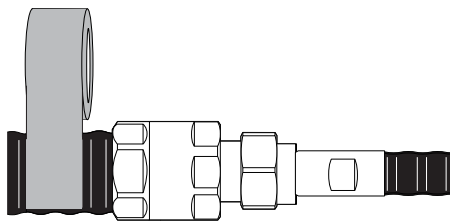

3/4" (19 mm) plastic tape wrap

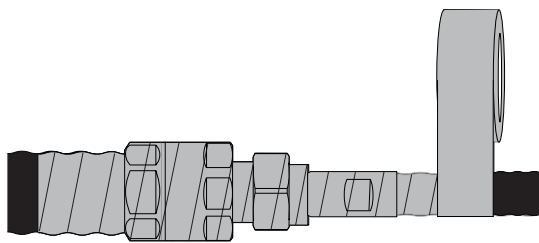

Tape overlap half width

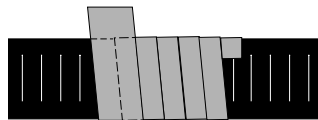

3 Start wrapping a layer of rubber tape 1" (25 mm) below the plastic tape, overlapping at half width. Pull the tape as needed for overlap. Press the tapes together along the overlaps.

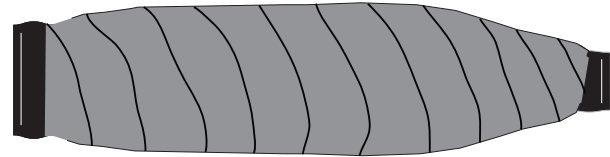

Rubber tape wrap

4 Wrap the connection with three continuous layers of 3/4" (19 mm) plastic tape. Overlap each tape to half-width and extend the wrapping 2" (51 mm) beyond the previous tape.

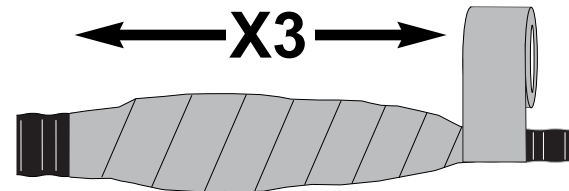

3/4" (19 mm) plastic tape wrap

WK-CNT applications versus cable & connectors

Cables	N-N	DIN-DIN
195-195	5	4
240-240	5	4
300-300	4	3
400-400	4	3
600-600	2	2
400-300	4	3
400-600	2	2

Notice: Andrew disclaims any liability or responsibility for the results of improper or unsafe installation, inspection, maintenance, or removal practices.

Aviso: Andrews no acepta ninguna obligación ni responsabilidad como resultado de prácticas incorrectas o peligrosas de instalación, inspección, mantenimiento o retiro.

Avis : Andrew décline toute responsabilité pour les conséquences de procédures d'installation, d'inspection, d'entretien ou de retrait incorrectes ou dangereuses.

Hinweis: Andrew lehnt jede Haftung oder Verantwortung für Schäden ab, die aufgrund unsachgemäßer Installation, Überprüfung, Wartung oder Demontage auftreten.

Atenção: A Andrew abdica do direito de toda responsabilidade pelos resultados de práticas inadequadas e sem segurança de instalação, inspeção, manutenção ou remoção.

Avvertenza: Andrew declina eventuali responsabilità derivanti dall'esecuzione di procedure di installazione, ispezione, manutenzione e smontaggio improprie o poco sicure.

注意 Andrew 公司申明對於不恰當或不安全的安裝、檢驗、維修或拆卸操作所導致的后果不負責 何義務和責任



Andrew Corporation
10500 West 153rd Street
Orland Park, IL U.S.A. 60462

Telephone: 708/349-3300
FAX (U.S.A.): 1-800/349-5444
Internet: <http://www.andrew.com>

Customer Service, 24 hours: U.S.A. • Canada • Mexico: 1-800/255-1479
U.K.: 0800 250055
Other Europe: +44 592 782 612

Printed in U.S.A. 7/06

Copyright © 2006 by Andrew Corporation