

E14R00P16

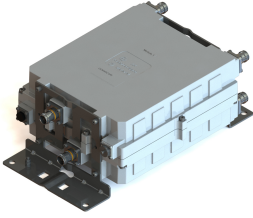

Dual Band Tower Mounted Amplifier, 800/900 MHz, 12 dB, 2 BTS & 4 ANT ports, AISG with 1 RET connector, with 4.3-10 connectors (1 device with 2 sub-units)

- Designed to boost UP-Link Coverage and KPIs
- TMA is operating in AISG & CWA mode, Alarm Current consumption CWA mode 190 mA
- 2 input ports and 4 output ports
- 1 device with 2 sub-units
- Single AISG with 1 RET connector
- New 4.3-10 connectors for improved PIM performance and size reduction

Product Classification

Product Type 1-BTS:2-ANT (Diplex) | Tower mounted amplifier

General Specifications

Color Gray

Modularity 2-Twin

Mounting Pipe Hardware Band clamps (2)

RF Connector Interface 4.3-10 Female

Dimensions

Height 250 mm | 9.843 in

Width 278 mm | 10.945 in

Depth 128 mm | 5.039 in

Mounting Pipe Diameter Range 42.6–122 mm

Outline Drawing

E14R00P16

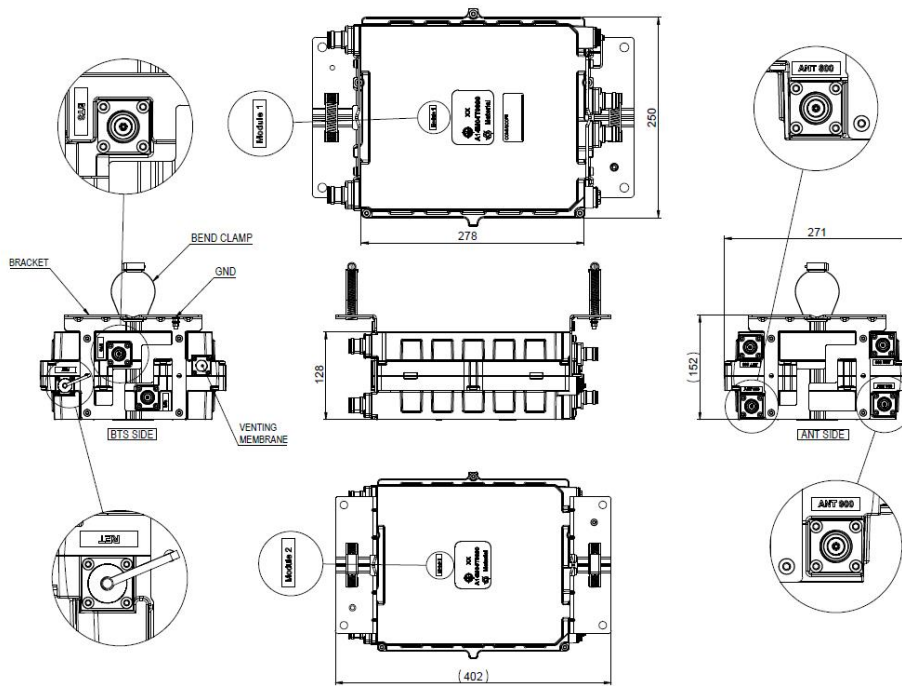

Electrical Specifications

License Band, LNA CEL 900 | EDD 800

Electrical Specifications, dc Power/Alarm

| | |
|---|---------------|
| dc Switching/Redundancy | Yes |
| Lightning Surge Current | 10 kA |
| Lightning Surge Current Waveform | 8/20 waveform |
| Voltage | 7–30 Vdc |
| Alarm Current, CWA Mode | 190 mA ±10 mA |

Electrical Specifications, AISG

| | |
|--------------------------------|------------------|
| AISG Connector | 8-pin DIN Female |
| AISG Connector Standard | IEC 60130-9 |
| Protocol | AISG 2.0 |
| Voltage, AISG Mode | 10–30 Vdc |

Electrical Specifications

Sub-module

1 | 2

1 | 2

E14R00P16

| | | |
|---------------------------------|--------------|--------------|
| Branch | 1 | 2 |
| Port Designation | ANT 800 | ANT 900 |
| License Band | EDD 800, LNA | CEL 900, LNA |
| Return Loss, typical, dB | 20 | 20 |

Electrical Specifications Rx (Uplink)

| | | |
|--|----------------|----------------|
| Frequency Range, MHz | 832–862 | 880–915 |
| Bandwidth, MHz | 30 | 35 |
| Gain, nominal, dB | 12 | 12 |
| Noise Figure, typical, dB | 1.25 | 1.25 |
| Group Delay Variation, maximum, ns | 165 | 165 |
| Group Delay Variation Bandwidth, MHz | 5 | 5 |
| Total Group Delay, maximum, ns | 240 | 240 |
| Return Loss, minimum, dB | 16 | 18 |
| Insertion Loss - Bypass Mode, typical, dB | 2.7 | 2.7 |

Electrical Specifications Tx (Downlink)

| | | |
|---|----------------------|----------------------|
| Frequency Range, MHz | 791–821 | 925–960 |
| Bandwidth, MHz | 30 | 35 |
| Insertion Loss, typical, dB | 0.75 | 0.75 |
| Group Delay Variation, maximum, ns | 60 | 65 |
| Group Delay Variation Bandwidth, MHz | 5 | 5 |
| Total Group Delay, maximum, ns | 110 | 110 |
| Return Loss, minimum, dB | 18 | 18 |
| Return Loss, typical, dB | 20 | 20 |
| Input Power, RMS, maximum, W | 200 | 200 |
| Input Power, PEP, maximum, W | 2000 | 2000 |
| 3rd Order PIM, typical, dBc | -156 | -156 |
| 3rd Order PIM Test Method | Two +43 dBm carriers | Two +43 dBm carriers |

Block Diagram

E14R00P16

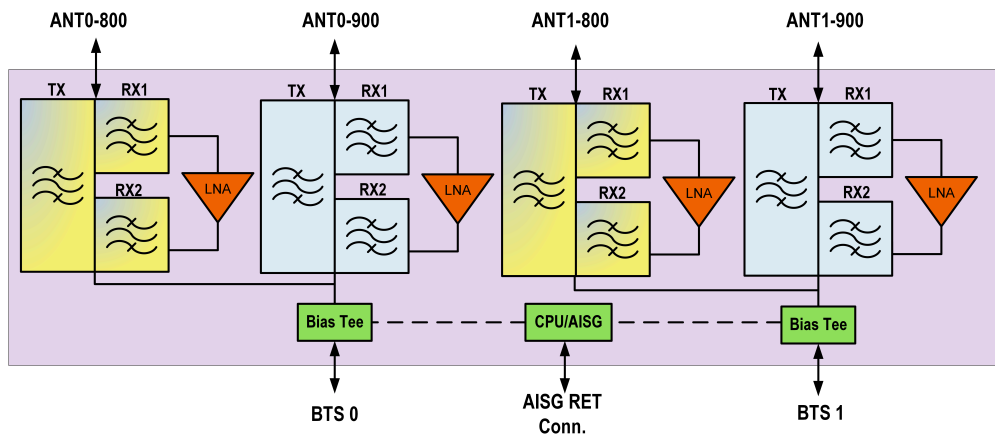

Environmental Specifications

| | |
|---------------------------------------|--------------------------------------|
| Operating Temperature | -40 °C to +65 °C (-40 °F to +149 °F) |
| Relative Humidity | Up to 100% |
| Corrosion Test Method | IEC 60068-2-11, 30 days |
| Ingress Protection Test Method | IEC 60529:2001, IP67 |

Packaging and Weights

| | |
|--------------------|---------------------|
| Included | Mounting hardware |
| Volume | 8.9 L |
| Weight, net | 12.2 kg 26.896 lb |

Regulatory Compliance/Certifications

| | |
|---------------|--|
| Agency | Classification |
| ISO 9001:2015 | Designed, manufactured and/or distributed under this quality management system |



* Footnotes

| | |
|--------------------------|--|
| License Band, LNA | License Bands that have RxUplink amplification |
|--------------------------|--|