

REVISIONS				
REV.	ECO	DESCRIPTION	BY	DATE
A	MTW	INITIAL RELEASE	ACG	11/07/07

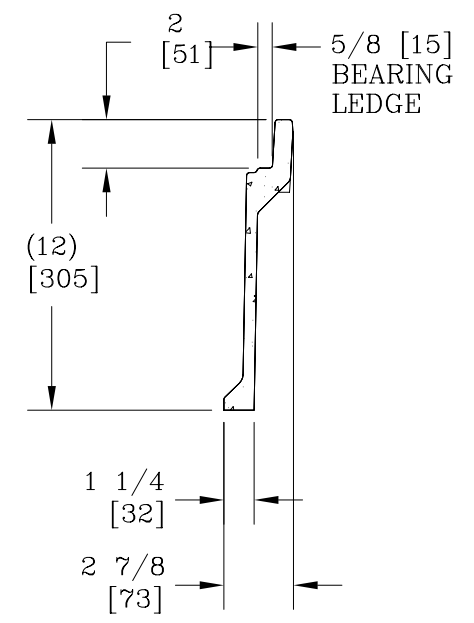

SECTION A-A

3/8-16 UNC SELF ALIGNING,
REPLACEABLE S.S. EZ-NUT
2 PLACES

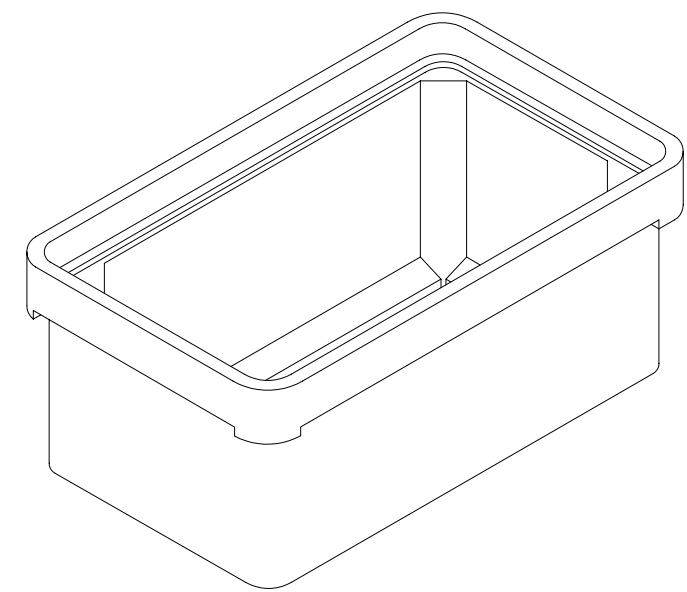
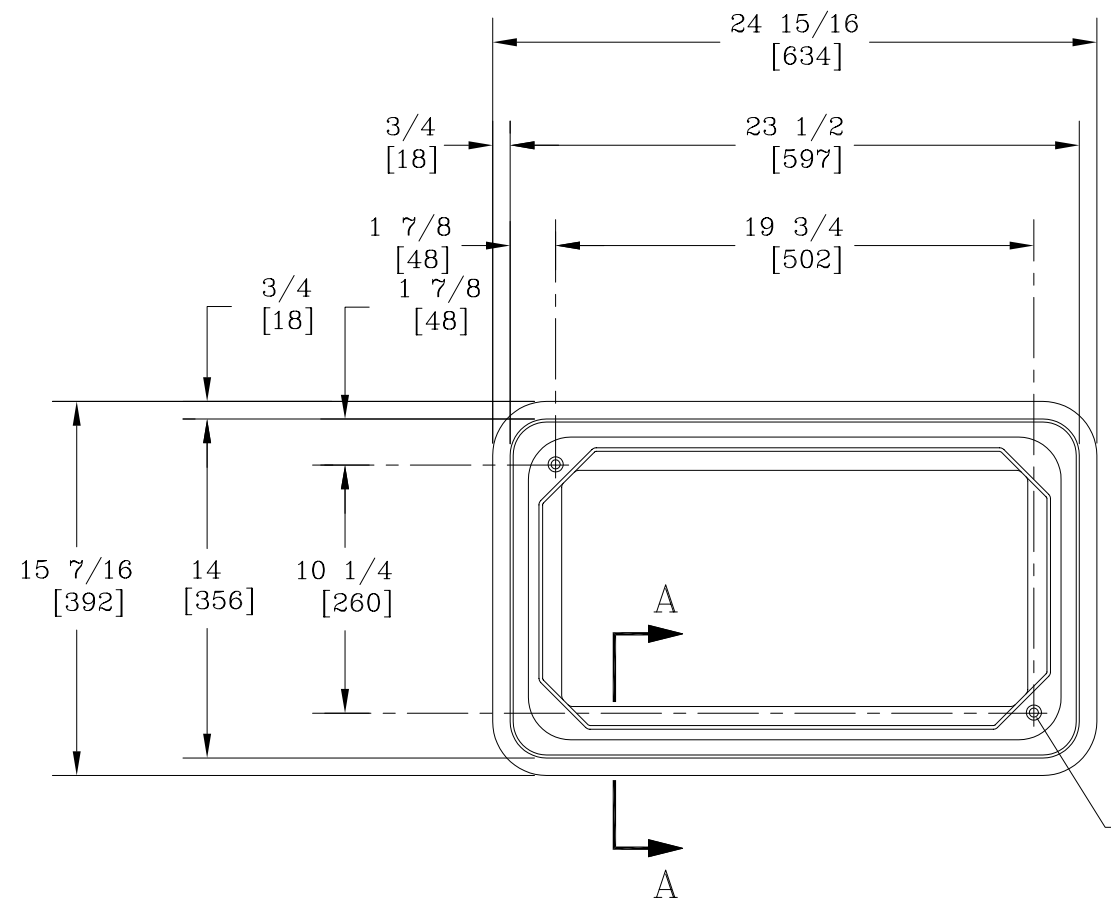
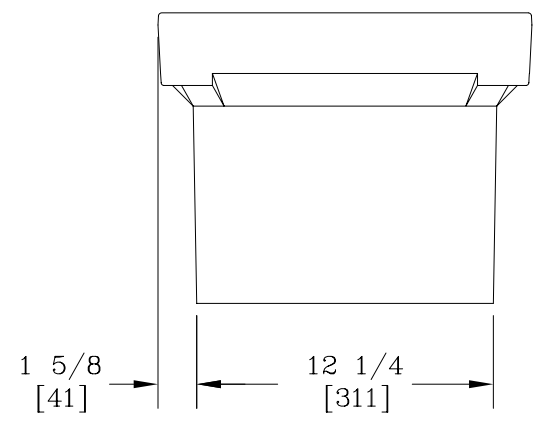
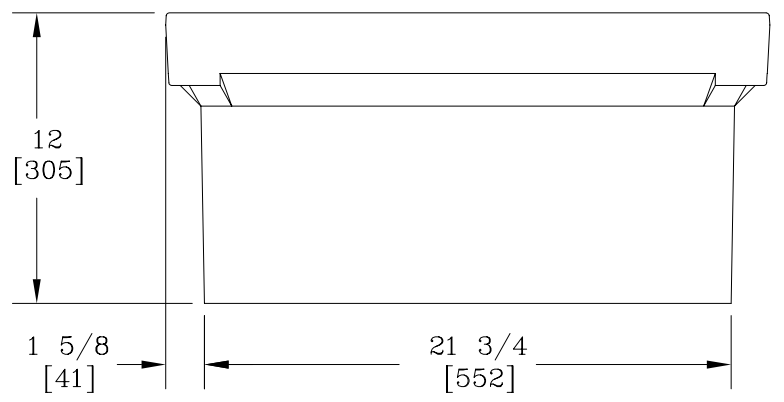

NOTES:

1. ALL METRIC DIMENSIONS ARE IN BRACKETS.
2. WEIGHT = 51 LBS



These drawings and specifications are the proprietary property of ANDREW CORPORATION and may be used only for the specific purpose authorized in writing by Andrew Corporation. ALL DIMENSIONS ARE IN INCHES U.O.S. TOLERANCES UNLESS OTHERWISE SPECIFIED: .X = ±.06 ANGLES ±2° .XX = ±.03 FRACTIONS ±1/32 .XXX = ±.010 REMOVE BURRS AND BREAK EDGES .005 DO NOT SCALE THIS PRINT	DRAWN BY: ACG	DATE: 11/07/07	PART NUMBER: MTC97681324
	CHECKED BY: TP	SHEET: 1 OF 1	DESCRIPTION: 13" X 24" GROUNDING VAULT
	REVISION: A	SCALE: NTS	Drawing Type: Assembly Drawing
	MATERIAL: A36	FINISH: Galv A123	 ORLAND PARK, IL. 60462 U.S.A.

REVISIONS				
REV.	ECO	DESCRIPTION	BY	DATE
A	MTW	INITIAL RELEASE	ACG	11/07/07

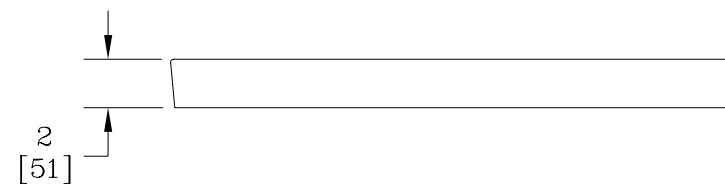
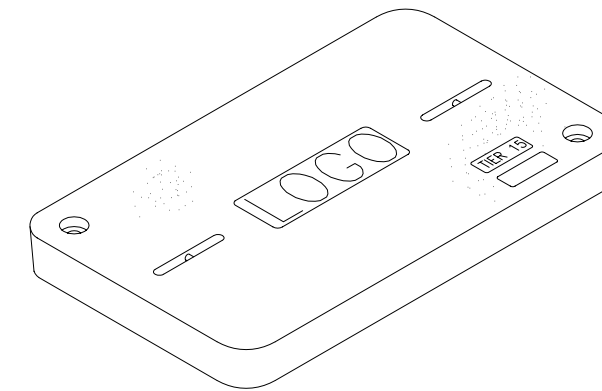
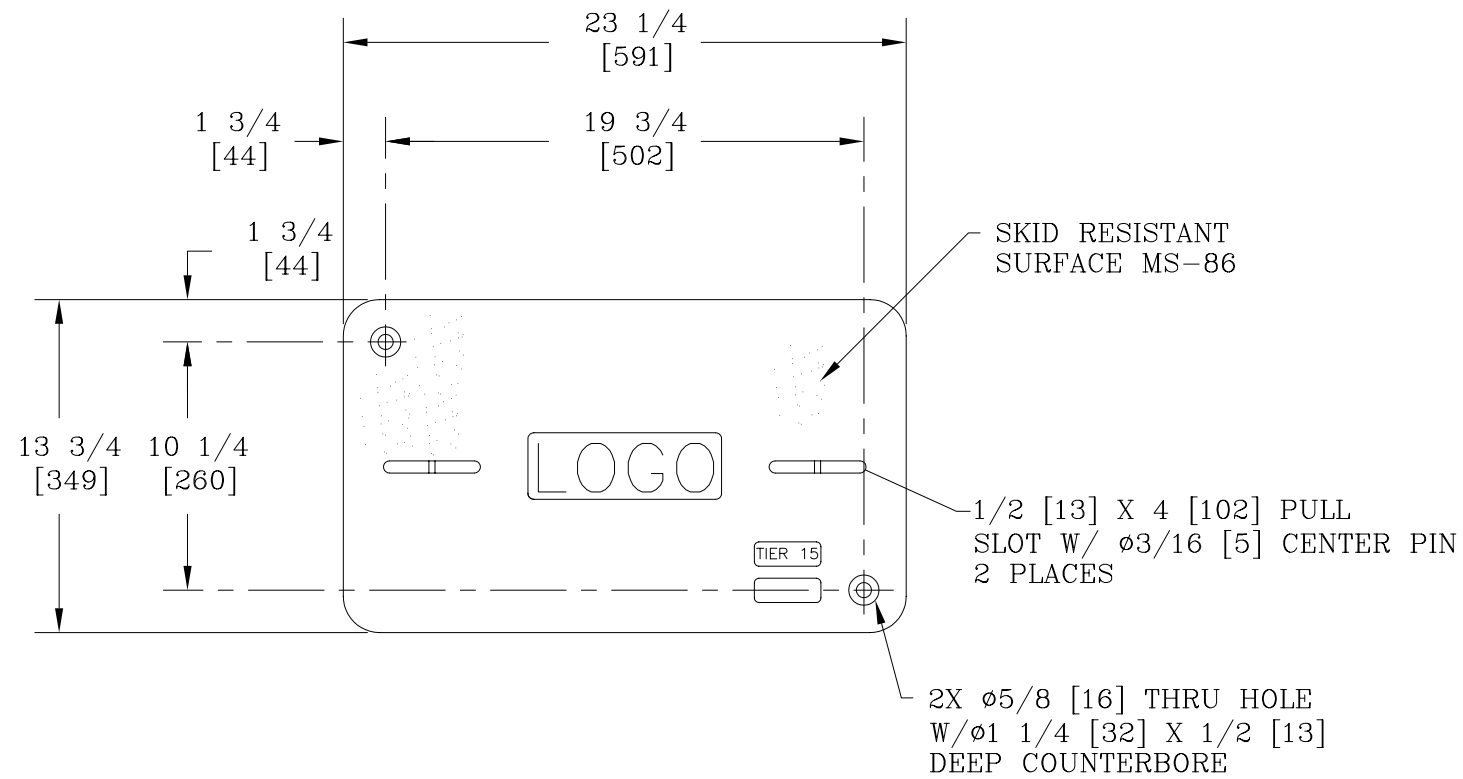



NOTES:

- LOGO TO BE SPECIFIED: N/A
- FURNISHED W/ (2) 3/8-16 UNC X 3 [76] LONG HEX HEAD BOLTS AND (2) 3/8 [10] FLAT WASHERS.
- THIS COVER IS RATED FOR A STATIC DESIGN LOAD OF 15,000 LBS. [66,720 N] OVER A 10 [254] X 10 [254] AREA AND MUST PASS A MIN. STATIC TEST LOAD OF 22,500 LBS. [100,085 N].
- DIMENSIONS IN BRACKETS ARE IN MILLIMETERS UNLESS OTHERWISE NOTED.

NOTES:

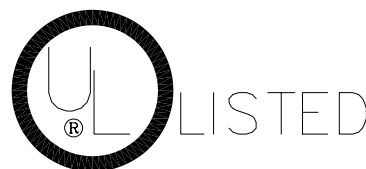
- ALL METRIC DIMENSIONS ARE IN BRACKETS.
- WEIGHT = 51 LBS



<small>These drawings and specifications are the proprietary property of ANDREW CORPORATION and may be used only for the specific purpose authorized in writing by Andrew Corporation.</small> <small>ALL DIMENSIONS ARE IN INCHES U.O.S. TOLERANCES UNLESS OTHERWISE SPECIFIED: .X = ±.06 ANGLES ±2' .XX = ±.03 FRACTIONS ±1/32 .XXX = ±.010 REMOVE BURRS AND BREAK EDGES .005</small> DO NOT SCALE THIS PRINT	DRAWN BY: ACG	DATE: 11/07/07	PART NUMBER: MTC97681324
	CHECKED BY: TP	SHEET: 1 OF 1	DESCRIPTION: 13" X 24" GROUNDING VAULT COVER
	REVISION: A	SCALE: NTS	Drawing Type: Assembly Drawing
	MATERIAL: A36	FINISH: Galv	 ORLAND PARK, IL. 60462 U.S.A.