



2-Post Equipment Rack Assembly Instructions

General

The 2-post equipment racks are industry standard 19 inch (483mm) and 23 inch (584mm) wide racks available in 7-foot (2.1m), 8-foot (2.4m), and 9-foot (2.7m) heights with either aluminum or steel vertical uprights (rails). Aluminum uprights include 12-24 tapped holes that accept 12-24 x 1/2" mounting screws (provided). Steel uprights include punched holes that accept M6 cage nuts and M6 x 12 mm mounting screws (both provided). The 2-post racks are designed to withstand a 1000 lb. (454 Kg) centered static load.

Ordering information is provided below:

Part Number	Material ID	Description
RK3-45A	760082479	45U Rack, aluminum rails, 3" x 7' (76mm x 2.1m)
RK3-52A	760082487	52U Rack, aluminum rails, 3" x 8' (76mm x 2.4m)
RK3-52A-23	760159749	52U Rack 23" (584mm) wide, aluminum rails, 3" x 9' (76mm x 2.7m)
RK3-58A	760139113	58U Rack, aluminum rails, 3" x 9' (76mm x 2.7m)
RK3-58A-23	760142364	58U Rack 23" (584mm) wide, aluminum rails, 3" x 9' (76mm x 2.7m)
RK6-45A	760082495	45U Rack, aluminum rails, 6" x 7' (152mm x 2.1m)
RK6-52A	760082503	52U Rack, aluminum rails, 6" x 8' (152mm x 2.4m)
RK12-45A	760082511	45U Rack, aluminum rails, 12" x 7' (305mm x 2.1m)
RK12-52A	760090100	52U Rack, aluminum rails, 12" x 8' (305mm x 2.4m)
RK3-45S	760090118	45U Rack, steel rails, 3" x 7' (76mm x 2.1m)
RK3-52S	760090126	52U Rack, steel rails, 3" x 8' (76mm x 2.4m)
RK6-45S	760090134	45U Rack, steel rails, 6" x 7' (152mm x 2.1m)
RK6-52S	760090142	52U Rack, steel rails, 6" x 8' (152mm x 2.4m)
RK6-58S	760139121	58U Rack, steel rails, 6" x 9' (152mm x 2.7m)
RK12-45S	760090159	45U Rack, steel rails, 12" x 7' (305mm x 2.1m)
RK12-52S	760090167	52U Rack, steel rails, 12" x 8' (305mm x 2.4m)
RK12-58S	760139139	58U Rack, steel rails, 12" x 9' (305mm x 2.7m)

WARNING

Legal Disclaimer: It is highly recommended that installation of this product be performed by a qualified and experienced installer. Improper installation of this product could result in damage to the product, other equipment, or personal injury. **CommScope** cannot be held responsible for damage to equipment or personal injury resulting from improper fastening or misuse of information presented in this document. **Racks must be wired per applicable sections of the National Electrical Code (NEC). If grounding is required, appropriate grounding hardware approved by the NEC must be used.**

How to Contact Us

- To find out more about **CommScope**[®] products, visit us on the web at <http://www.commscope.com/>
- For technical assistance:
 - Within the United States, contact your local account representative or technical support at 1-800-344-0223. Outside the United States, contact your local account representative or Authorized Business Partner.
 - Within the United States, report any missing/damaged parts or any other issues to **CommScope** Customer Claims at 1-866-539-2795. Outside the United States, contact your local account representative or Authorized Business Partner.

Tools Required

- 9/16" Socket
- 9/16" Box-end wrench
- Carpenters square

Parts List

Verify parts against the parts list below:

Quantity		Description	Quantity		Description
Steel Rails	Aluminum Rails		Steel Rails	Aluminum Rails	
2	2	Vertical rack rails	12	12	3/8 split lock washers
2	2	Extruded base angles	–	40	12-24 x 1/2" mounting screws*
2	2	Extruded top angles	40	–	M6 x 12 mm mounting screws*
12	12	3/8-16 UNC x 1" hex head bolts	40	–	M6 cage nuts
12	12	3/8-16 hex nuts	1	1	Instruction sheet

* Recommended torque for 12-24 and M6 screws is 30 in-lb. (3.4 N-m).

Assembly

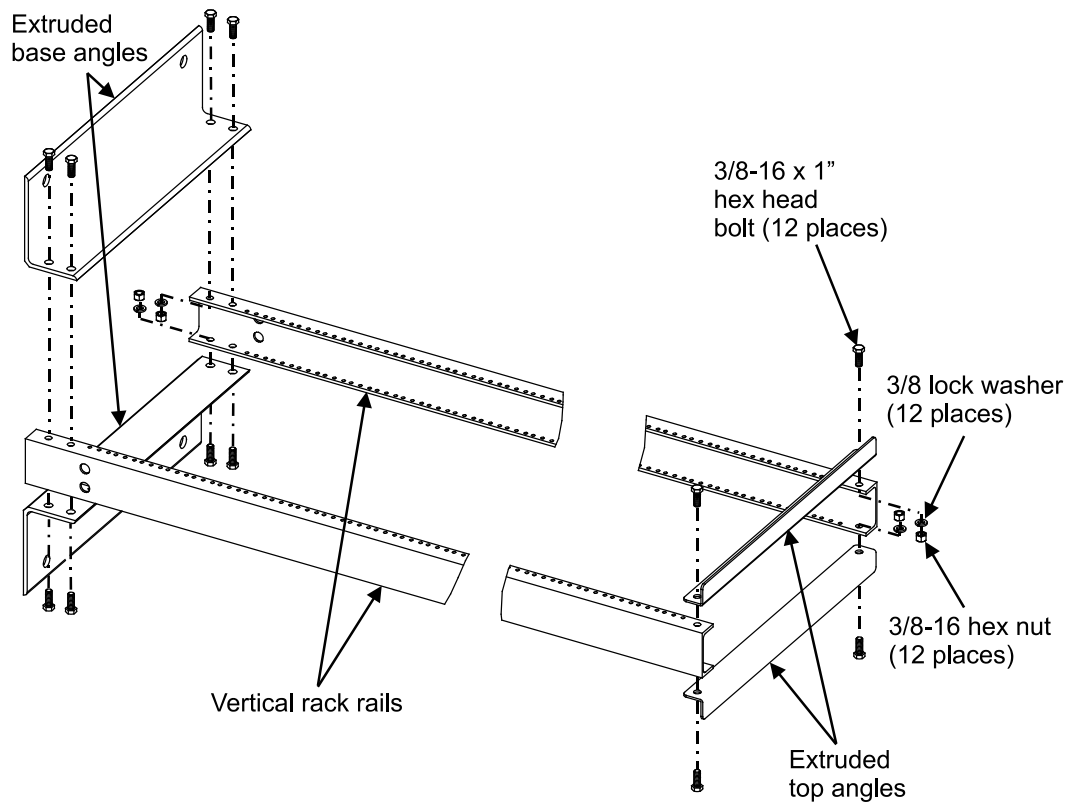

1. Lay both vertical rack rails flat on floor with flanges facing each other as shown on page 2.
2. Position one base angle and one top angle on channels as shown and insert six 3/8-16 x 1 hex head bolts, 3/8" lock washers, and 3/8-16 hex nuts. **Hand-tighten only.**
3. Turn assembly over and position second base angle and top angle as shown. Insert six 3/8-16 x 1 hex head bolts, 3/8" lock washers, and 3/8-16 hex nuts. **Hand-tighten only.**

4. Using a square, align the channels, top angles and the base angles to square the rack and to obtain a panel mounting hole spacing for a 19-inch rack.
5. Tighten all 3/8" bolts securely.
6. Stand rack upright, making sure the supports are still square with the top and base angles.

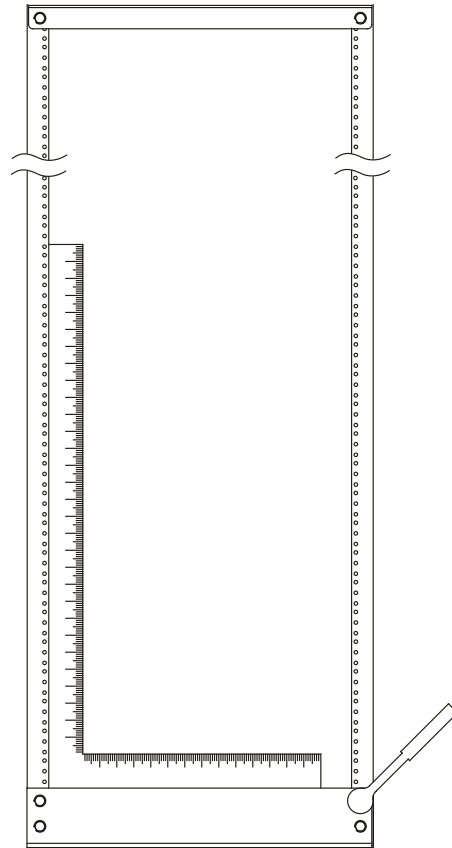

Installation

Note: Racks are approved for mounting on concrete or other non-combustible surfaces.

1. The equipment rack must be securely anchored to the floor or to an equally stabilized and secure surface using approved mounting hardware
2. The structural integrity of the rack will only be as good as the quality of the rack to floor attachment. Using improper sized anchors or failing to secure all floor bolts can result in structural failure and possibly personnel injury.
3. Racks tend to be top heavy and as such should be anchored as soon as possible to avoid the possibility of tipping over. **Never install equipment until the rack is fully locked down and secured to the floor.**